



TIN 'N BRASS

MONTHLY NEWSLETTER
ONTELAUNEE AACA
OFFICIAL CHAPTER OF THE AACA



*Photo Credit: Minnie Breininger
1957 Fairlane Ford*

In Loving Memory: Carl R. Breininger

One year ago, we said goodbye to Carl R. Breininger — but his life, his stories, and his legacy still drive on in every mile, every memory, and every Studebaker he loved.

I met Carl at the Allentown Fair in 1958. At the time, he didn't have a car of his own and had to borrow his father's Studebaker. He wanted to make MANY trips to Krumsville. That's where I lived. It wasn't long before he bought a 1952 Ford. I learned to drive in that car... after almost upsetting it in a curve.

Next, he bought a 1957 Ford Fairlane.

When Carl needed a job, Mr. Carl L. Mayers from Kuhnsville Garage hired him. He worked there part-time until he was out of school and then went full-time. I think the year was 1959. We were married in 1960 and lived in a trailer in Seipstown. He worked long hours, so I sometimes had to take him dinner. One night

I had to deliver one of those dinners. The only vehicle we had available was the 1949 yellow double-clutch Studebaker wrecker. I packed up our young son, Craig, in his little steering-wheel car seat and brought along our trusty dog, Dusty, and headed to Kuhnsville. Driving a double-clutch truck wasn't easy to begin with, and with a child and dog in tow, it was quite a trip. It was so foggy that I had to hang my head out the window just to see well enough to drive.

Around 1965, we purchased the garage and became full-time owners. We pumped Texaco gas, sold new Studebaker cars, and handled full-service car repairs.



1949 Studebaker

Continued on page 6

Table of Contents

Next Meeting: January 3, 3 pm

Zion's New Jerusalem UCC,
Lenhartsville

In Loving Memory: Carl Bringinger	Page 1
President's Page	Page 2
From the Editor's Desk	Page 3
Make the Swap Meet Happen	Page 3
From Membership Chair	Page 4
Birthdays & Anniversaries	Page 4
Secretary's Report	Page 4
Classic Parts, Modern Searches	Page 7
Officers & Chairpersons	Page 8
Calendar of Events	Page 8
Tour Info	Page 9
AACA National Convention	Page 10
Tour Registration Forms	Page 11

ontelauneeaca.com

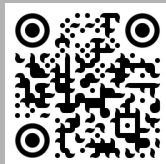

The Tin & Brass is the official publication of the **Ontelaunee Region of Pennsylvania AACA**. We are a chapter of the Antique Automobile Club of America, Hershey, Pennsylvania. This newsletter is published monthly. Members may choose to receive the newsletter via email or postal mail.

Any items contained herein may be reproduced if proper credit is given. *All articles are edited for length, grammar, accuracy, and composition.* They will be used at the discretion of the editor and Region officers. Please advise the editor of all the corrections that are needed.

Articles are due on 2nd Thursday of each month.

Cheri Dotterer, editor

202 Donne Road, Hamburg, PA 19526

newsletter@ontelauneeaca.com

for the web - webmaster@ontelauneeaca.com

President's Message A Bigger Picture

Nearly 500 antique vehicle enthusiasts—men, women, teenagers—from over 20 states and Canada came together in Chantilly, Virginia, during the first full weekend in February to talk about, learn about, and share stories about their vehicles and the hobby that means so much to them. I want to share some of the information, ideas, and insights I gathered during my participation in the AACA Annual Convention.

For example, I was intrigued by a presentation on transportation history; a program put together to interest school children in the development of ways to move people and things. In the nineteenth century, New York City ran on 150,000 to 200,000 horses. It looks quaint in the movies, but that many horses produced more than 100,000 tons of manure and 10,000,000 gallons of urine each year. And, more than 15,000 horses died in service every year, many on the street where their bodies were abandoned to decompose. Things didn't get better with the advent of the railroad and steamboat—horse-drawn vehicles were still needed to deliver people and things to these forms of mass transport. It was the automobile that overcame this environmental nightmare, even though the auto then contributed to the next ecological crisis.

Canva is a free-to-use online graphic design tool that helps create media with a unified look across all print and digital communications, to help make a program or message more successful. Mailchimp or MailerLite can be used in the same way to automate communication and marketing, and to analyze what works and what doesn't. (Cheri uses these tools daily.)

People today are scrolling well before they're strolling into car shows or other car club activities. It's important to use social platforms—photos, videos, live streaming—to boost visibility before, during, and after events, as well as for the vehicle hobby in general. In this important way the AACCA, its regions, and clubs are not about cars: they're really about connecting to and with people. We ought to develop a wider perception of what we are and wish to be.

*perception (par-'sep-shan)
—to become aware or
conscious of something; to
come to realize or
understand*



~Tim Hinkle

From the Editor's Desk

Seeing what matters

This month's articles may seem different on the surface, but they share a common thread. Minnie reminds us of the grit and determination that built this hobby. Jeff takes us to the swap meet aisle, where preparation and knowledge still matter.

Tim pulls the lens back even farther. From national convention conversations to the way we communicate today, he challenges us to think about where the hobby is going, not just where it has been.

Ultimately, we are preserving more than just metal and chrome. We are preserving stories, skills, and connections. When we keep that bigger picture in mind, the future of the hobby looks much stronger.



~Cheri Dotterer

Help Make the Swap Meet Happen

One of the things that makes our Swap Meet special isn't just the parts, the vendors, or the crowds—it's the members who show up early, lend a hand, and help create a welcoming experience for everyone involved. This is where AACCA's offer becomes visible in action.

We will need volunteer help on **Saturday, February 28, 2026**, starting at 7:00 AM, to assist with setup for the meet and show and to help vendors find their assigned spaces. Coffee will be available in the morning, and we'll share some pizza for lunch as a thank-you.

On **Sunday, March 1**, we'll need early-morning help beginning at **5:00 AM** to guide vendors to their spaces so everything is ready when the public arrives at **7:00 AM**. We will also need members to help collect entrance fees as guests arrive. Because we'll be staffing two entry points, extra hands make a real difference.

Volunteering is one of the simplest ways to contribute to the success of the Swap Meet—and to be part of the experience that keeps people coming back year after year. If you're able to help, please call Jeff Dotterer.

And don't forget to bring your White Elephant items—they're always part of the fun.

Thank you for helping make the Swap Meet welcoming, organized, and successful for everyone.



~Lester Manwiller

Lester - 610-823-4656

Jeff - 610-914-4808



From your Membership Chair

NATIONAL MEMBERSHIPS AVAILABLE

We have four free memberships to offer to individuals who have never been AACA members. If you know anyone interested, please have them contact me. I will make sure they receive the necessary paperwork.

Those who choose to take advantage of this offer must also join Ontelaunee. This is a one-year membership, so please enroll as soon as possible to take full advantage of the offer.

KEEP ME INFORMED

If you have any corrections to your information in the future, please let me know so I can keep the membership rolls up to date. It is also important to keep your roster current by adding new members and removing those who pass away or choose not to renew. If we keep our records current, it will be easier for anyone needing to contact our members.

I rely on you for these updates. If someone is in the hospital or on the sick list, please let me know. If a club member has passed away, I would also greatly appreciate a phone call.



Contact: Phyllis Peters
5265 Elgen Drive, Emmaus, PA 18049
610-965-9236 | phyllispeters@hotmail.com

March Birthdays



- 3 Warren Fick
- 4 Fern Fegely
- 5 Susan Manwiller (Matt.)
- 9 Marilyn Roth
- 9 Ann Keck
- 11 Brian Stever
- 19 Robert Squitieri
- 24 Phyllis Peters
- 28 Elaine Baer
- 29 John Rome

HAPPY BIRTHDAY

March Anniversaries

- 16 Robert Squitieri / Ann Keck
- 26 Wayne & Patti Schaffer



Secretary's Report

Vice President Mike Wolfe called the meeting to order on February 7, 2026, at the New Jerusalem Zion UCC Church in Krumsville, PA, at 3:00 pm, followed by the Pledge of Allegiance to the American flag. There were 22 people present.

Susan Manwiller gave the Secretary's report from the business meeting held on January 3, 2026. A motion to approve the Secretary's report was made by Elaine Baer and seconded by Marilyn Roth. The motion carried.

Lester Manwiller gave the Treasurer's report for January 2026. A motion to approve the Treasurer's report was made by Shirley Schaffer and seconded by Ray Huber. The motion carried.

COMMITTEE REPORTS

Membership

Membership Dues: Phyllis Peters submitted the membership report to AACA, showing 139 members. Phyllis will provide Cheri with a list of members to remove from the membership roster, and they will no longer receive the newsletter. She was unable to contact John Heyer.

Roster: Please keep your roster up to date with any changes. There will be a new roster in 2027.

Sick List: A get-well card will be sent to Carol Allen, who underwent knee surgery. Ray Huber will have knee surgery later this month.

National Memberships: Phyllis has four free National memberships available to anyone who would like to join and has not previously been a member of AACA.

Website: Cheri Dotterer reported for Michael Dotterer. In January, there were 374 new users who viewed the following: home page, swap meet, newsletters, photo gallery, and calendar.

Newsletter: Cheri has someone lined up for the March feature article. If anyone knows of local events, please email her to include them in the newsletter. Cheri learned from an email from AACA President Dave Anspach that progress was made on our publication. It was only a few points shy of Master Editor.

Activities: Suzy McGovern reported that she has bakers signed up for the entire year.

- Early Bird Tour – Friday, March 6, 2026 – Tour Masters Bob and Florita Hobaugh are going to the Eastern Museum of Motor Racing.
- Apple Blossom Tour – Sunday, May 17, 2026 – Special Olympics Benefit Car Show @ A.D. Moyer Lumber, Kutztown.
- Church Tour – Tour Master Tim Hinkle
- Picnic Tour – Tour Masters Neil and Audrey Merkel
- Dog Days Tour – Open
- Three-Day Tour – September 11, 12, 13 – Tour Masters Mike and Donna Wolfe to Lukan's Farm Resort. A \$200 room deposit is needed by the end of February. All checks collected so far will be turned over to the Treasurer. If someone's check isn't cashed, give Donna a call in case it got lost in the mail.
- Fall Foliage Tour – Open
- Applejack & Cider Tour – Open

Leesport Swap Meet: March 1, 2026 – Lester Manwiller has 49 indoor and 59 outdoor spaces sold so far. He will call any vendors who have not renewed. There will be an indoor food vendor this year. The outdoor vendor will be the same as last year.

Jeff Dotterer oversees parking and will need people to man the gates. He hopes the snow melts or the market does a better job of plowing it. For the 2026 swap meet, there will be a separate entrance and exit, which will require additional help. Let Jeff know if you can help.

Thanks to Neil Merkel for donating larger money pouches for use at the gates.

Das Awkscht Fescht: Chairman Bob Hobaugh was absent; the Secretary read a report outlining the progress he made. Some of the highlights from that report include:

1. Bob has been attending every former Dorney Park racers' meeting.
2. He is promoting DAF by distributing registration forms and postcards at the AACA National meeting in Chantilly, VA, and at the AACA display booth at the Philadelphia Auto Show.
3. He's been getting quotes on tents.
4. He would like someone to attend the Reading Fairgrounds Race Car driver's reunion at Beltzner Hall in Kutztown Fairgrounds on February 27-28. Jeff will be going.
5. On Friday, March 6, Bob and Florita will lead us to the Eastern Museum of Motor Racing for the Early Bird Tour. Since we want their support at DAF, Bob would like a good turnout for this tour.
6. Amy will have a Fescht meeting on February 24 at 7:00 pm at the park.
7. Bob would like a third registration tent for day-of-show registrations.
8. Bob would like to accept credit cards for day-of-show registrations. There will be an Ontelaunee Fescht committee meeting on February 16 to discuss the cost of the Fleetwood Bank credit card and its feasibility.

Susan reported 398 vehicles registered so far this year, 10 more than last year at this time, and 88 flea market spaces sold, 10 less than last year at this time.

NEW BUSINESS

1. There were many questions about items in the DAF report: who pays for the feature tents if we don't have enough sponsors; will we have to pay for a credit card machine; and why would a tent for day-of-show registration cost so much? Credit card machine questions will be answered when we meet with the Fleetwood Bank on February 16.
2. There was a discussion about advertising on Facebook. Some members thought the park was responsible for all advertising. Cheri said that, to advertise effectively, we need a Facebook page. Members have been advertising by posting on their personal Facebook page, limiting the number of people who see it. Jeff is the administrator of the Ontelaunee Facebook group, where Jeff and Bob post, but only our members see what is posted.
3. On a Facebook page, we could post the swap meet, DAF, tours, and meetings, and link to Eventbrite.
4. A motion was made by Cheri Dotterer, seconded by Neil Merkel, to create a Facebook page. The motion carried. Jeff will do it for free, and there is no charge from Facebook.

Thanks to Minnie Breininger and Ruthann Krause for refreshments.

A motion to adjourn the meeting at 4:03 pm was made by Jeff Dotterer and seconded by Suzy McGovern. The motion carried.

Next meeting is March 7 at 3:00 p.m.

Respectfully submitted,

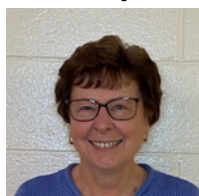

~Susan Manwiller, Secretary

Carl Breininger continued

Continued from page 1

When Studebaker went out of business in 1963, we began selling new Dodge vehicles through Hahn & Sons in Lehighton, but Studebakers always held a special place in Carl's heart.

Over the years, we drove, sold, and accumulated many Studebakers. At one point, we even had a salvage yard full of them. I wanted Carl to sell some of the cars before he passed, but that wasn't what he wanted to do. They weren't just cars to him; they were history, craftsmanship, and memories.

Today, I still have seven Studebakers:

- 1941
- 1949
- 1950 (all original)
- 1951
- 1960 (white)
- 1964
- and a 1964 Buick.



1950 Studebaker

Some are in need of repair, but most are pretty nice, just like the life we built together.

Carl wasn't just a mechanic or a car dealer. He was a hardworking husband, father, and business owner. He believed in showing up, putting in long hours, and doing things the right way. He built a life around engines, family, and faithfulness, steady and dependable. A year later, his legacy endures.

Every time one of those engines turns over, it feels a little like hearing his voice again.



1941 Studebaker



1964 Studebaker

~Minnie Breinginger

Classic Parts, Modern Searches

The Swap Meet Advantage

So far, we've talked almost exclusively about shopping for classic car parts on the internet. While that's certainly the newest and often the most misunderstood way to find what you need, it's obviously far from the only method.

There's also the traditional approach: attending a swap meet. Events like Carlisle, Hershey, or just in time for our March show, the Ontelaunee Swap Meet, are still some of the best places to track down hard-to-find parts. For over 60 years, this has been "the way" enthusiasts found what they needed.

Yes, the internet has replaced some of that. But if you're like me, even if some purchases now happen online, you still prefer the old method: finding the part on someone's table, picking it up, feeling it in your own hands, trading cash, and taking it home with you. No shipping. No damage. No fraud. No surprises.

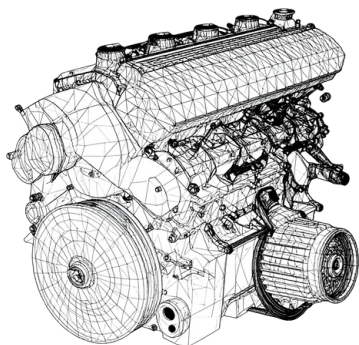

If you're going to swap meets, there are a few things you learn quickly. First and foremost: know exactly what you're looking for. You can't expect the seller to know every part on his table or what each one fits. For example, I might have a trunk lid from a '69 Chevelle I parted out, but I may not know it also fits 1968–1972 Chevelles, 1970–1972 Monte Carlos, and even certain 1970–1972 Buick Skylarks. I just know it came off a '69. The interchange is often up to you. You'll also run into sellers who genuinely don't know, and guess. A part they believe came from a '69 Chevelle may actually have come from a '71 Impala. And unfortunately, some less-than-honest sellers may tell you what you want to hear just to make the sale. That's why it's better to ask, "What do you know this fits?" instead of "Will this fit my '82 DeLorean?" Knowing for yourself is always better than relying on someone else's memory.

Swap meets are early events. If you're planning to go, plan on beating the rooster out of bed. Most open at first light. I used to say at Carlisle: if you were driving into town and the sun was already above the mountain, you were too late.

Things have changed a bit over the years, but getting there early still helps you avoid traffic jams, sometimes 20 times the normal number of people trying to enter a small town at once. And remember: the early bird gets the worm. Many of the best deals are made first thing in the morning. Once they're sold, they're gone.

Bring plenty of cash. Most swap meet vendors don't take credit cards.

Make a list of what you're looking for, and make it broad. The bigger your list, the better your odds of finding something worthwhile. If you're hunting for only one specific item, your chances are slim.

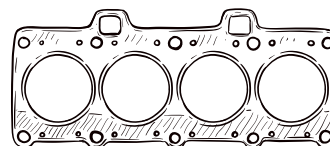

Above all, treat it like a treasure hunt. Look inside boxes. Check behind and under tables. Many parts are tucked out of sight. Don't be afraid to get your hands dirty.

And most importantly, have fun. There's nothing quite like the rush of finding exactly what you were looking for less than the price of a Big Mac.



~Jeff Dotterer

2026 Events

See ontelauneeaca.com for details

Monthly Chapter Meetings are held at
3:00 pm.

Zion's New Jerusalem UCC,
1456 Krumsville Rd, Lenhartsville, PA
19534

Meetings are held January-May,
September-November

NO Meetings June-August, December

March

March 1: Leesport Swap Meet
March, FRIDAY 6: Early Bird Tour -
Bob & Florita Hobaugh

March 7: Chapter Meeting

April

April 4: Chapter Meeting



2026 Officers and Board Members

President	Tim Hinkle
1st V. President	Michael Wolfe
2nd V. President	Leroy Hinkle
Secretary	Susan Manwiller
Treasurer	Lester Manwiller
Board Chair	Jeff Dotterer
Directors	Elaine Baer
	Shirley Schaffer
	Marilyn Roth
	Ray Huber

2026 National Events

March 19-21, 2026

Guaynabo,

Suayabo, Puerto Rico S Puerto Rico Region

March 26-28, 2026

Winter Nationals

Cartersville, Georgia • Lake Allatoona Region

April 9-11, 2026

Southeastern Spring Nationals

Charlotte, N.C. • Hornets Nest Region

April 23-25, 2026

Annual Grand Nationals/Western Spring Nats

Las Vegas • Las Vegas Region

2026 Events in Eastern PA

March 7 – Carbon County Hot Wheels Club Swap Meet – Heritage Center in Summit Hill, PA.

March 14 – Mid Atlantic Indoor Nationals – Indoor vehicle show at Greater Philadelphia Expo Center, Oaks, PA (Saturday and Sunday March 21–22 as well).

March 14 – Spring Swap Meet – Maple Grove Raceway, Mohnton, PA

March 28 – Kies Auto Show / Season Opener – Maple Grove Raceway, Mohnton, PA

2026 Committee Chairpersons

Activities	Suzy McGovern
DAF	Bob Hobaugh
DAF Registration	Susan Manwiller
Membership	Phyllis Peters
Newsletter	Cheri Dotterer
Swap Meet	Lester Manwiller
Website	Michael Dotterer

Early Bird Tour



Date: *******FRIDAY, March 6, 2026** *****
Destination: Eastern Museum of Motor Racing, 100 Baltimore Road, York Spring, PA 17322 - <https://www.emmr.org>.

We will travel on 4-lane highways where we will see one of the best collections of vintage racecars, motorcycles, and memorabilia, including Lynn Paxton's sprint car, midgets, Offenhauser engines, and bodywork by Hiram Hillegass.

Meet: Dietrich's Meats, 660 Old 22, Krumsville, PA 19534
Time: 8:00 AM
Leave: 8:30 AM for tour
Guided Tour of EMMR: 10 AM - 12:00 noon
Lunch 12:30 PM: Lyndon Diner, 1353 Kenneth Road, York 17404
Deadline: Wednesday, February 25, 2026

Apple Blossom Tour



Date: May 17
Departure: Greenwich Elementary
Time: Arrive 6:45 am - Leave lot 7:15 am
Destination AD Moyer Kutztown Car Show -Benefiting the Special Olympics Berks County Softball
Breakfast: Airport Diner, Kutztown
Tour Host: Jeff and Cheri Dotterer
Registration form: Coming Next month

Guest Speaker: Steve Reinert will be joining us at our March Meeting to share more about this event.

Bakers for Meetings

MARCH

1. Donna Wolfe
2. Suzy McGovern



APRIL

1. Barbara Todd
2. Barbara Koch

2026 Three Day Tour



Sept 11, 12 & 13, 2026

Lukans Farm Resort – 2-night stay
 \$320.00 per person (double occupancy)
\$200.00 per room non-refundable deposit by Feb 28, 2026

Additional meals & activities
 \$130.00 per member
 \$180.00 per non-member
 Trip total (double occupancy)
 Members – \$450.00 per person
 Non-members – \$500.00 per person

Carl Breinger's Cars



1951 Studebaker



1960 Studebaker



Carl's Garage, Kuhnsville, PA

AACA Annual Meeting 2026

Florita and I joined Ontelaunee President Tim Hinkle and First Lady Sue Hinkle at the annual meeting of the AACA, February 4-8, in Chantilly, Virginia. We arrived at the Westfield Marriott Dulles on Wednesday to join the Washington, D.C. tour at 10 am on Thursday. That bus tour included stops at the Capitol, the Lincoln, Washington, and Jefferson Monuments, and the Reflecting Pool. Later, we visited the trade show and distributed flyers for Das Awkscht Fescht.

Friday, Tim and Sue attended the first Lady's luncheon while Florita and I toured the Museum of the American Indian and the Air & Space Museum. Tim spoke proudly about our Ontelaunee Region at the Regions and Chapters dinner that night, presented a gift to the AACA, and touted the Fescht.

Saturday, we attended the National Judging School and Team Captains' CJE. All four of us attended a course on Club use of social media. Tim has some good ideas.

At the General Membership meeting, Tim, Sue, Florita, and I sat with incoming AACA President Vicki Bolton and her husband, Art. That evening, our own John McCarthy received an AACA award at the National Awards Banquet. Our Perkiomen AACA Treasurer, Bill Walker, received a national award for the Harley-Davidson he displayed at the Charlotte event. Mark Serfass of the Boyertown Museum of Historic Vehicles picked up an award for the Museum and one for his own vehicle.

We proudly greeted Dave and Deb Ansbach at their last meeting as President and First Lady of AACA. They represented us well and will continue to serve the AACA.



~Bob Hobaugh



Ontelaunee President Timothy Hinkle presenting chapter donation



John McCarthy receives AACA award for his service from Dave Ansbach



Incoming President, Vicki Bolton, accepts gavel from outgoing President, Dave Ansbach

Cost Members including immediate family: \$25, 6-12 \$5, Under 6 Free

Tour Registration Forms

Checks Payable to Ontelaunee Region AACA

Non-Members: Actual cost of the event

Three Day Tour Deposit \$200

DEADLINE: February 28, 2026

Transferable - NOT Refundable

Three Day Tour - September 11, 12, 13, 2026

Lukans Farm Resort lukans.com (\$900 per couple)

includes two family style breakfast and two family style dinners

Tour: Hawley Honesdale and Wallenpaupack, PA

TOTAL COST: Members \$450 per person/non-members \$500

Additional meals and activites

You must be a member for 1 year before getting member pricing for three day trips

Members' Names: (\$200 deposit per room) _____

Non-Members' Names: (\$250 deposit per room) _____

Children 6-12: (\$200) _____ Children under 6: _____

Phone Number: _____

Email: _____

Amount Enclosed: _____ Check #: _____

Mail form to: Mike & Donna Wolfe

8204 Holbens Valley Road, New Tripoli, PA 18066 | 610-298-8001

Early Bird Tour

FRIDAY, March 6, 2026

DEADLINE: WEDNESDAY, February 25, 2026

Members' Names: (\$25) _____

Non-Members' Names: (\$25) _____

Children 6-12: (\$5) _____ Children under 6: _____

Phone Number: _____

Email: _____

Amount Enclosed: _____ Check #: _____

Mail form to: Bob & Florita Hobaugh

| Bob 610-360-6537

710 East Walnut Street, Kutztown, PA 19530

| Florita 610-360-6538

Cheri Dotterer
editor: Tin 'n Brass
P.O. Box 354
Hamburg, PA 19526

RETURN SERVICE REQUESTED

TO :



Ontelannee Region

We are dedicated to the preservation, restoration and maintenance of antique cars, trucks and motorcycles.

DEPOSIT DUE FEB. 28

THREE DAY TOUR

EARLY BIRD DUE FEB. 25

March
March 1: Leesport Swap Meet
March, FRIDAY 6: Early Bird Tour -
Bob & Florita Hobough
March 7: Chapter Meeting

Tin 'n Brass

Antique Automobile Club of America